



BATTALION RANGE

Recessed



Surface Mount



- Extremely Arduous & Resilient to Weather/Attack
- Heavy Gauge Steel Galvanised Body & Frame
- Regressed Gasketed Bezel, Captive 10mm Polycarbonate Diffuser
- Surface or Recess Mount Versions
- Removable LED Gear Tray

Linear & Trunking

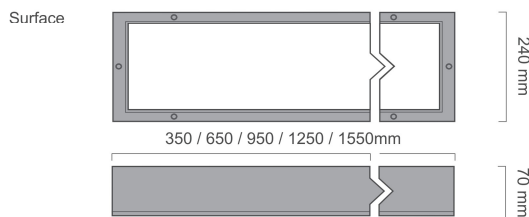
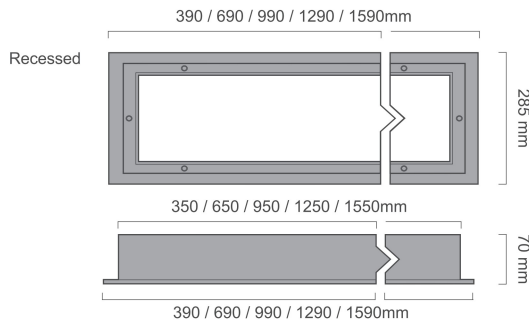

Standard Fixing Detail

- 4qty x 6mm Ø Back Body Corner Mounting Holes
- 1qty x 20mm Ø Back Body Centre Cable Entry Hole

Linear LED Technical Information

Please refer to website for current LED technical specification

Order Code	Length	Lumens		lm/W		Circuit wattage (HO)	Colour Temp Kelvin (K)	Ra	Weight Kg
		HE	HO mm	HE	HO				
BAT 1.0	2.0	350	1000lm	2000lm	115	11.1 - 20.2	3000K/4000K	>80	6.0
BAT 1.3	2.6	650	1300lm	2600lm	115	13.8 - 25.2	3000K/4000K	>80	8.0
BAT 1.9	3.9	950	1950lm	3900lm	112	19.9 - 37.4	3000K/4000K	>80	10.0
BAT 2.6	5.2	1250	2600lm	5200lm	110	26.1 - 49.8	3000K/4000K	>80	12.0
BAT 3.2	6.5	1550	3250lm	6500lm	108	32.6 - 62.7	3000K/4000K	>80	14.0

LED Life-time 50,000Hr L80/B10 (@ 25°C - 40°C)

Ordering Options

Description	Suffix Ordering Code
Surface Mounted Body Version	/BAT-SM
Recess Mounted Body Version	/BATR-RM
Exterior Fully Weatherproof Version	/EXT
Dimmable Options (DALI/1-10v/Sw-240v/Corridor)	/DALI / 1-10v / SW-240v / CORR
Integral 3hr Emergency or 3hr Self Test	/EM3 or /EM3-SELF
Microwave Motion Detection	/M-Wave
Night Light	/NL
Frosted Diffuser	/F
Clear Stippled Diffuser	/P
Security Driver/Key	/SD
Stainless Steel Version (316/304/430 Grades)	On Request
LED Linear Tube Gear Tray (240v Mains)	/GT-LEDT5